

# Print To Mail 2

## User Guide

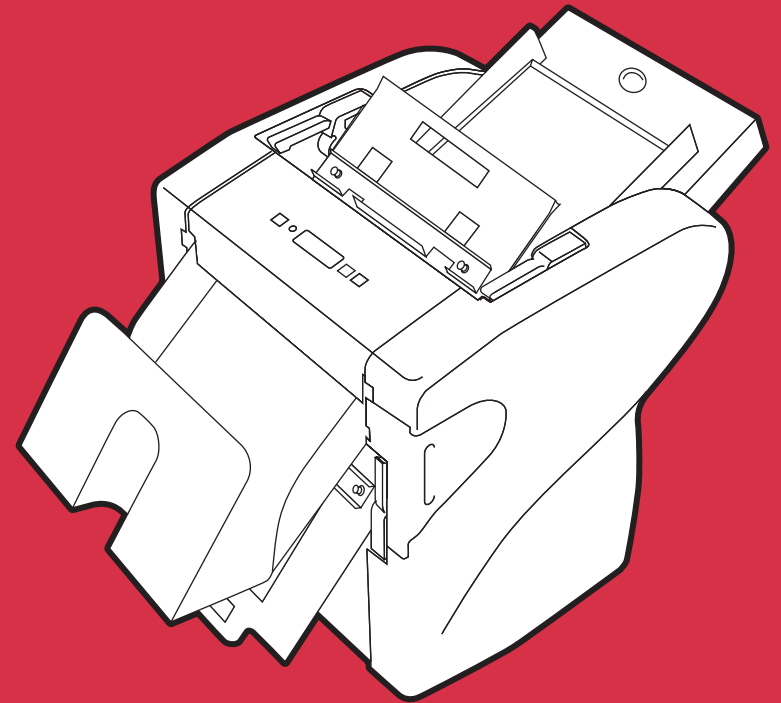

# Print ToMail 2

## User Guide

### Contents

#### Setup Pages

A. Package Contents .....	pg 1
B. Identifying parts.....	pg 2
C. Installing Fold Chutes .....	pg 3
D. Installing Exit Tray .....	pg 3
Adjusting the Fold Chutes.....	pg 4
Loading Documents .....	pg 5
Ready to Run .....	pg 6
Troubleshooting .....	pg 7
Clearing Jams .....	pg 8
Maintenance.....	pg 8
Specifications .....	pg 9
Regulatory Information.....	pg 9
Service and Support.....	pg 9

### Specifications

---

#### Dimensions:

Height (with Upper Fold Chute installed)	18.5"
Width	16.25"
Depth (with Exit Tray installed)	28"
Weight	60 lbs.
Paper Size	8.5" x 11" & 8.5" x 14"
Paper Lift Tray Capacity	Up to 250 sheets, varies with document weight; up to 28 lb. paper

Fold Types	C, Eccentric C, Z, Eccentric Z, V
Fixed Speed	3000 sheets per hour (11" length)
Rated Duty Cycle	30,000 per month
Required Power	110 V., 60 Hz., 15 Amp service
In-line Fuse	2 Amp

### Regulatory Information

---

Regulatory Agency Compliance	UL, CUL, FCC Class B
------------------------------	----------------------

### Service and Support

---

Please contact your local sales representative for current service and support information, or call PTM Document Systems: (866) 667-2861

1. Press Stop button.
2. Remove Fold Chutes, and Exit Tray if necessary. Clear any paper jammed in the Fold Chutes.

3. Pull open the Slide Access Door on the side cover, and turn the Jam-Clearing Knob clockwise or counter clockwise to feed out any document(s) stuck in the rollers of the machine. Slide back and close Access Door.

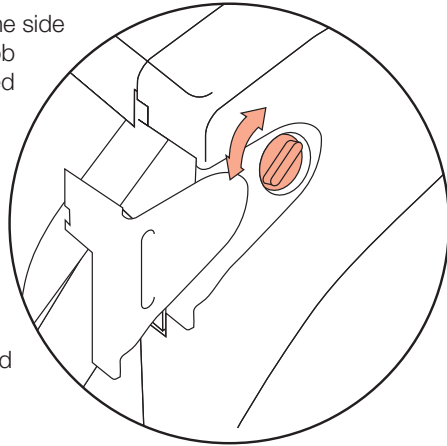

4. Check Fold Chute settings for the documents and check the stack of documents in the Paper Lift Tray to make sure they are feeding straight.
5. Replace Fold Chutes and Exit Tray and press Start button to continue.

**Maintenance**

1. Place the power ON/OFF switch in OFF (down) position and remove power cord.
2. Clean exterior of **PTM 2** when necessary with damp cloth.
3. Clean the Fold Chutes, Exit Tray, Paper Lift Tray, and folding/sealing rollers above the Exit Tray by following these instructions:
  - a) Remove the Exit Tray & Fold Chutes and dust them to remove any paper dust build-up. Dust Paper Lift Tray as needed.
  - b) Clean the steel folding/sealing rollers by opening the Slide Access Door and turning the Jam-Clearing Knob counter-clockwise while wiping the rollers with a lint-free cloth.

Turning the Knob *clockwise* while cleaning the rollers with a cloth **should not be done.**

4. Clean rubber feed roller in Paper Lift Tray with a lint-free dampened cloth.

Package Contents

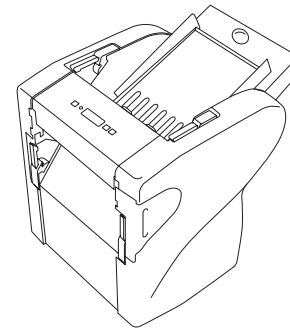

PTM 2  
Main Unit

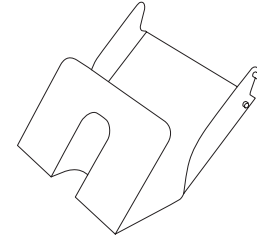

Exit Tray

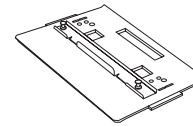

Upper Fold Chute/  
Diverter (Settings 1-5)

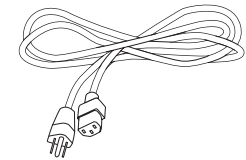

Power Cord

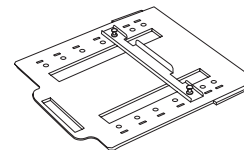

Lower Fold Chute  
(Settings A-H)

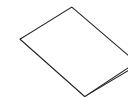

Quick Setup  
Card

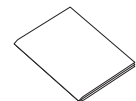

User Guide

Identifying Parts

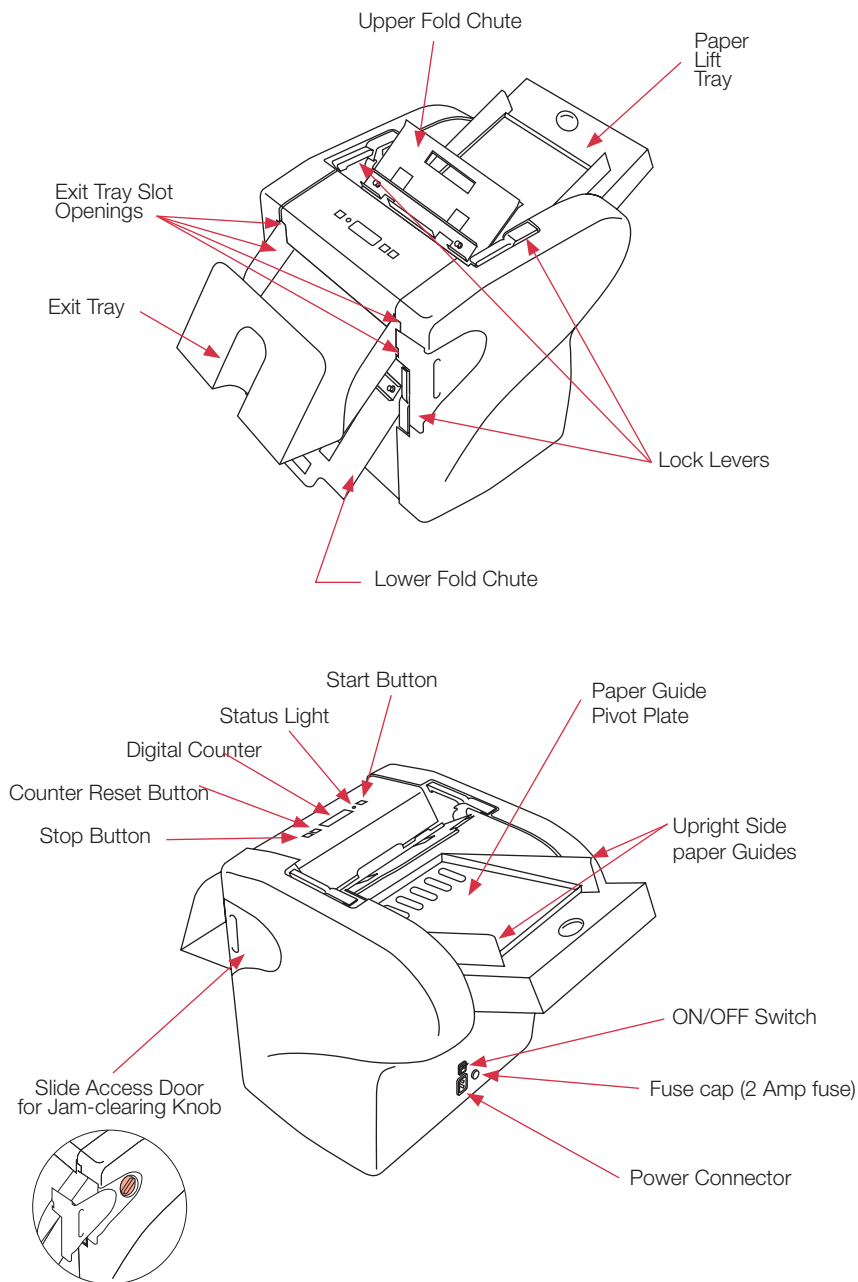

Problem	Cause	Solution
Document does not fold correctly.	Fold Chute settings are incorrect.	Check Fold Chute Settings Matrix for correct setting for this document.
	Documents placed incorrectly in Paper Lift Tray.	Change orientation of documents in Paper Lift Tray.
Document does not seal correctly.	Check Causes and Solutions above.	Rollers may need to be cleaned; see Maintenance in next chapter.
	Old or out of date adhesive on documents	Check documents for adhesion and replace as necessary.
No Power to Machine	Power cord not plugged into wall outlet or not securely plugged into machine.	Check power cord at both ends to make sure it is plugged into outlet and machine securely.
	Power switch in OFF position	Place power switch in ON (up) position.
	Fuse blown	Replace fuse, 2 Amp, under fuse cap (near Power Switch).
Motors do not run when Start is pressed and digital counter is on	Exit Tray not seated properly and/or Slide Access Door not closed.	Make sure Exit Tray pegs are fully down in their slots, and Access Door is slid back to closed position.
Machine stops in mid-run of folding documents, Status Light is on.	Exit Tray is full	Remove folded documents from Exit Tray, press Start button and folding will continue.
	Document has jammed in machine and/or Fold Chute	Follow jam-clearing instructions in next section.
Documents misfeeding in Paper Lift Tray	Documents sticking together	Remove stack of documents, fan the stack at both ends, replace stack properly in Paper Lift Tray.
	Document stack is too large for Paper Lift Tray	Remove a quantity of documents from stack, make sure remaining stack is neat and under roller.
	Uneven document stack in Paper Lift Tray.	Remove stack of documents, tap sides of stack to make it straight & even, replace stack properly in Paper Lift Tray.
	Bent corners on documents at leading edge.	Remove stack and flatten corners of documents and straighten stack. Replace stack properly in Paper Lift Tray.
	Top document leading edge not under feeding roller.	Gently press stack of documents down on Paper Lift Tray so leading edge of top document is properly under feeding roller.
Upright side paper guides on Paper Lift Tray set too narrow for stack of documents.	Adjust the guides using 5/32" hex key to loosen cap screws. Slide guides so they just touch sides of stack. Gently tighten cap screws.	



